

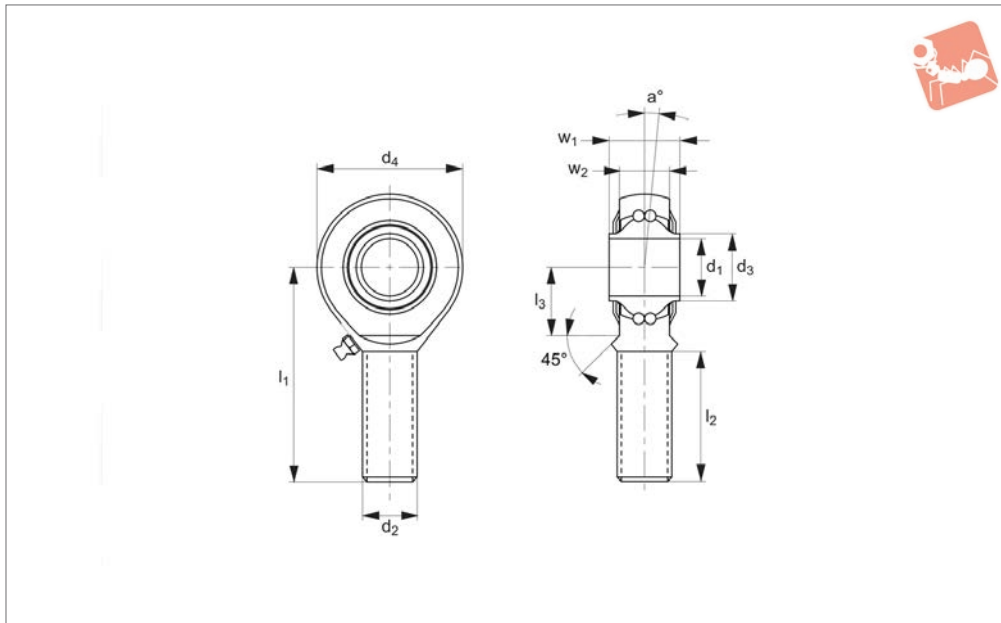

# Heavy-Duty Rod Ends - Male with integral ball bearing

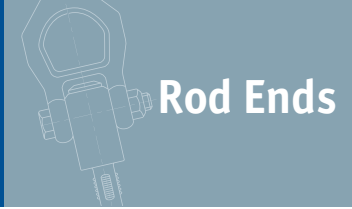

## 65740

ROD ENDS

### Material

Housing - forged steel, tempered, case hardened bearing race, ground and lapped, rolled thread, surface galvanized.  
Inner ring - ball bearing steel, hardened, superfine ground, lubrication - calcium-complex-soap-grease, temp range -20°C to +120°C.

Lubrication nipple - DIN 3405 D1/A (sizes 6 to 10) DIN 71412 H1 (sizes 12 to 30).

technical pages.

### Tips

Standard thread is right hand thread.

### Technical Notes

Low maintenance. Sizes according to DIN ISO 12240-4 series K, for tolerances see

### Important Notes

\*Denotes fine pitch thread.

Order No.	Thread hand	d <sub>1</sub>	l <sub>1</sub>	d <sub>2</sub>	d <sub>3</sub>	l <sub>2</sub>	d <sub>4</sub>	a <sub>°</sub>	l <sub>3</sub>	w <sub>1</sub>	Weight g
65740.W0106	Right	6	36	M6	9.0	22	20	8.0	12	9	19
65740.W0108	Right	8	42	M8	10.5	25	24	8.5	15	12	36
65740.W0110	Right	10	48	M10	12.0	29	28	8.0	15	14	60
65740.W0112	Right	12	54	M12	14.5	33	32	7.5	19	16	87
65740.W0114	Right	14	60	M14	17.0	36	36	6.0	20	19	135
65740.W0116	Right	16	66	M16	19.0	40	42	8.0	22	21	190
65740.W0118	Right	18	72	M18x1,5*	21.5	44	46	8.5	25	23	270
65740.W0120	Right	20	78	M20x1,5*	24.5	47	50	7.0	28	25	338
65740.W0122	Right	22	84	M22x1,5*	26.0	51	54	8.0	26	28	450
65740.W0125	Right	25	94	M24x2*	29.5	57	64	5.0	30	31	602
65740.W0130	Right	30	110	M30x2*	34.5	66	70	7.5	35	37	922
65740.W0206	Left	6	36	M6	9.0	22	20	8.0	12	9	19
65740.W0208	Left	8	42	M8	10.5	25	24	8.5	15	12	36
65740.W0210	Left	10	48	M10	12.0	29	28	8.0	15	14	60
65740.W0212	Left	12	54	M12	14.5	33	32	7.5	19	16	87
65740.W0214	Left	14	60	M14	17.0	36	36	6.0	20	19	135
65740.W0216	Left	16	66	M16	19.0	40	42	8.0	22	21	190
65740.W0218	Left	18	72	M18x1,5*	21.5	44	46	8.5	25	23	270
65740.W0220	Left	20	78	M20x1,5*	24.5	47	50	7.0	28	25	338
65740.W0222	Left	22	84	M22x1,5*	26.0	51	54	8.0	26	28	450
65740.W0225	Left	25	94	M24x2*	29.5	57	64	5.0	30	31	602
65740.W0230	Left	30	110	M30x2*	34.5	66	70	7.5	35	37	922

Order No.	w <sub>2</sub>	Calc. factor Y	Calc. factor Y <sub>0</sub>	Dyn. load C kN max.	Speed rpm max.	Static load C <sub>0</sub> kN max.
65740.W0106	6.75	2.19	2.09	2.75	1350	0.65
65740.W0108	9.00	1.89	1.80	4.00	1300	1.00
65740.W0110	10.50	1.81	1.90	4.45	1225	1.45

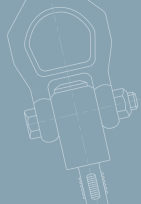

Order No.	w <sub>2</sub>	Calc. factor Y	Calc. factor Y <sub>0</sub>	Dyn. load C kN max.	Speed rpm max.	Static load C <sub>0</sub> kN max.
65740.W0112	12.00	1.82	1.74	4.95	1125	1.80
65740.W0114	13.50	2.48	2.36	5.60	1025	2.00
65740.W0116	15.00	2.35	2.24	6.25	975	2.35
65740.W0118	16.50	2.31	2.21	7.10	900	2.90
65740.W0120	18.00	2.58	2.46	7.90	825	3.45
65740.W0122	20.00	2.24	2.35	9.30	725	3.98
65740.W0125	22.00	2.12	2.02	11.03	600	5.68
65740.W0130	25.00	2.35	2.24	14.15	450	7.45
65740.W0206	6.75	2.19	2.09	2.75	1350	0.65
65740.W0208	9.00	1.89	1.80	4.00	1300	1.00
65740.W0210	10.50	1.81	1.90	4.45	1225	1.45
65740.W0212	12.00	1.82	1.74	4.95	1125	1.80
65740.W0214	13.50	2.48	2.36	5.60	1025	2.00
65740.W0216	15.00	2.35	2.24	6.25	975	2.35
65740.W0218	16.50	2.31	2.21	7.10	900	2.90
65740.W0220	18.00	2.58	2.46	7.90	825	3.45
65740.W0222	20.00	2.24	2.35	9.30	725	3.98
65740.W0225	22.00	2.12	2.02	11.03	600	5.68
65740.W0230	25.00	2.35	2.24	14.15	450	7.45

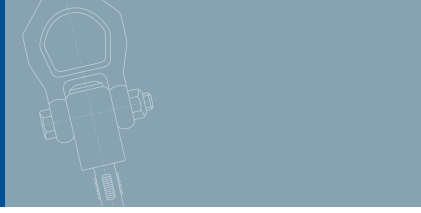

## Parts overview



### Heavy Duty Rod Ends: integral spherical plain bearings - series K and series E

Male and female rod ends, maintenance free. These are our most popular range of heavy duty rod ends. Bore diameters 5mm up to 30mm.

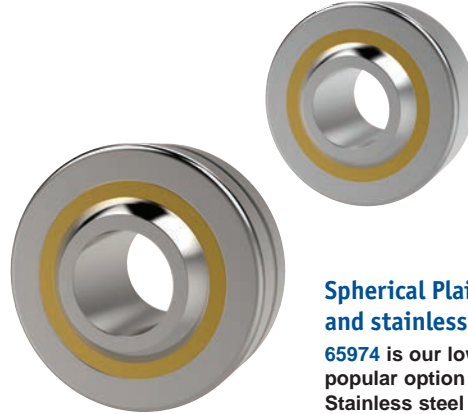

### Spherical Plain Bearings: steel and stainless steel

65974 is our lowest cost, most popular option spherical bearing. Stainless steel version 65976 requires maintenance. 65974 is maintenance free. Bore diameters 5mm up to 30mm.



### Heavy Duty Rod Ends: integral ball bearings - series K and series E

Male and female rod ends. Different bore sizes in relation to the thread size. All require maintenance. Bore diameters 6mm up to 30mm.

### Stainless Steel Heavy Duty Rod Ends: integral spherical plain bearings

Male and female rod ends maintenance free.



### Low Cost Rod Ends: with spherical plain bearing

These are our most popular male and female rod ends. Maintenance free. Female-bore diameters 5mm up to 12mm. Male-bore diameters 5mm up to 16mm.



### Rod Ends with Studs

Steel and Stainless steel, male and female, maintenance free. Sizes M6 up to M16.

see our website for our full range:  
[wixroyd.com](http://wixroyd.com)



All of our rod ends incorporate either a plain spherical bearing, ball bearing, or roller bearing. Below is an overview of each type.

### Plain spherical bearings

- ① Thin coating made from Polyamid-PTFE-fibreglass - compound, maintenance free, absorbs any foreign particles.
- ② Ball made of bearing steel, hardened, ground, polished and hard chromium plated, ensures reliable corrosion protection.
- ③ No clearance - radial clearance 0-10µm.
- ④ All rod end housings made of forged steel, tempered, extremely high load resistances.

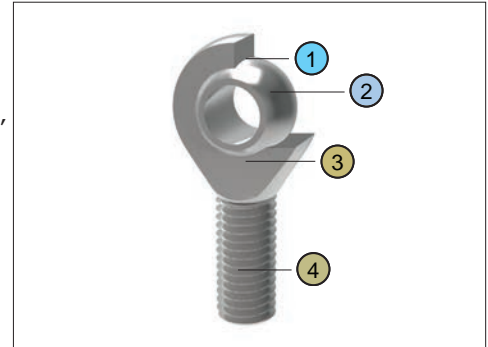

### Ball and roller bearings

- ① Radial clearance: 10-30µm, low friction.
- ② Inner ring made of bearing steel, hardened ball grooves polished.
- ③ Shields on both sides protect against rough dirt penetration.
- ④ All rod ends housings are made of forged steel, case hardened bearing race.
- ⑤ Low maintenance due to long-term greasing, especially suitable for high speed large swiveling angles or rotating movements.

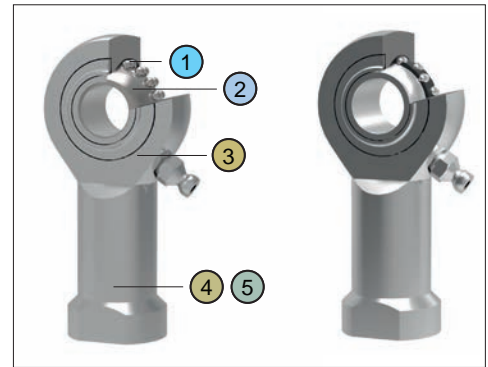

### Rod ends and water

#### Stainless steel versions

Most of our rod ends are available in stainless steel as standard.

High grade AISI 316 stainless steel available on request.



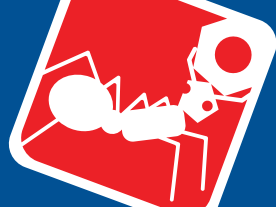

In many cases heavy-duty rod ends with integral spherical plain bearings are most often used. They are above all used for small swivelling or tilting movements at low speeds. They stand out for their high load capacity and can also be used for shock-like loads. The rod end ball slides on a plastic bearing shell consisting of a glass fibre-filled nylon/teflon compound. This design assures a maintenance-free rod end. Heavy-duty plain bearing rod ends have slight initial movement friction and virtually no clearance. The plastic material used has another advantage in that it can absorb many foreign particles so that no damage can occur. The balls of heavy-duty rod ends with integral spherical plain bearings are hard chrome plated. This reliable corrosion protection ensures that the function of the rod end will not be affected by a corroded ball surface under humid operating conditions.

This design is especially suitable for high speeds, large swivelling angles or rotating movements with relatively low or medium loads. Prominent technical features are the low bearing friction, long-time greasing as well as the sealing against some dirt penetration (by means of shields on both sides). Under normal operating conditions the rod ends are maintenance-free. Greasing nipples are provided for lubrication in case of rough operations and maximum loads. To avoid incompatibility with the production lubrication, we recommend lubrication with a calcium-complex-soap-grease. A special heat treatment procedure gives the rod end housing a raceway hardness adapted to the antifriction bearing, ensuring at the same time high stability with changing loads.

This design, based on the structure of a self-aligning roller bearing is preferably used for high speed, large tilting angles or rotating movements under high loads. Compared to rod ends with ball bearings, rod ends with self-aligning roller bearings essentially have higher basic load ratings. This design is equipped with a cage to minimise the rolling friction and heat build-up. These rod ends, with long-time lubrication are under normal operating conditions maintenance-free. Greasing nipples are provided for lubrication in case of rough operations and maximum loads. To avoid incompatibility with the production lubrication, we recommend lubricating with a calcium-complex-soap-grease. Shields on both sides limit dirt particles from penetrating into the bearing. The rod ends with roller bearings are subjected to a special heat treatment to obtain a raceway hardness adapted to the antifriction bearings, ensuring at the same time a high stability with changing loads.

## Rod end bearings load capacity explained

The static load capacity  $C_0$  is the radially acting static load which does not cause any permanent deformation of the components when the spherical bearing or rod end is stationary, (i.e. the load condition without pivoting, swivelling or tilting movements). It is also a precondition here that the operating temperature must be at normal room temperature and the surrounding components must possess sufficient stability.

The values specified in the tables are determined by static tension tests on a representative number of series components at 20°C normal room temperature. The static load capacity may vary with lower or higher temperature depending on the material. In the case of all rod ends with plain bearings, the static load rating refers to the maximum permissible static load of the rod end housing in a tensile direction up to which no permanent deformation occurs at the weakest housing cross-section. The value in the product tables has a safety factor of 1.2 times the tensile strength of the rod ends housing material.

For our rod ends with roller and ball bearings, the static load rating is the load at which the bearing can operate at room temperature without its performance being impaired as a result of deformations, fracture, or damage to the sliding contact surfaces (max 1/10,000<sup>th</sup> of the ball diameter).

Dynamic load ratings serve as values for calculation of the service life of dynamically-loaded spherical bearings and rod ends. The values themselves do not provide any information about the effective dynamic load capacity of the spherical bearing or rod end. To obtain this information, it is necessary to take into account the additional influencing factors such as load type, swivel or tilt angle, speed characteristic, max. permitted bearing clearance, max. permitted bearing friction, lubrication conditions and temperature, etc.

Dynamic load capacities depend on the definition used to calculate them. Comparison of values is not always possible owing to the different definitions used by various manufacturers, and because the load capacities are often determined under completely different test conditions.

For our rod ends with roller and ball bearings, the dynamic load capacity is the load at which 90% of a large quantity of identical rod ends reach 1 million revolutions before they fail (due to fatigue of the rolling surfaces.)

### Rod ends with integral maintenance-free spherical plain bearings

### Rod ends with integral ball bearings

### Rod ends with integral roller bearings

### Static load capacity $C_0$ (plain bearings)

### Static load capacity $C_0$ (roller and ball bearings)

### Dynamic load capacity C (plain bearings)

### Dynamic load capacity C (roller and ball bearings)

ov-W65700-AR3550-T-W65970-AR3630-T-c-rnh-Updated -31-10-2022



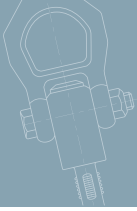

### Operating temperatures

Heavy-duty ball and roller bearing rod ends can be used for operating temperatures between  $-20^{\circ}\text{C}$  and  $+120^{\circ}\text{C}$ . The temperature range of heavy-duty rod ends with integral spherical plain bearing is between  $-30^{\circ}\text{C}$  and  $+60^{\circ}\text{C}$ , without affecting the load capacity. Higher temperatures will reduce the load capacity taken into account for the calculation of the 'working life' under the temperature factor  $C_2$  on page 451.

### Loads

The decisive parameters for the selection and calculation of heavy-duty rod ends are size, direction and type of load.

### Radial or combined loads

The heavy-duty rod ends have been especially designed to cope with high radial loads. They can be used for combined loads, the axial load share of which does not exceed 20% of the corresponding radial load.

### Unilaterally acting load

In this case the load acts only in the same direction, which means that the load area is always in the same bearing section.

### Alternately acting load

In case of alternating loads, the load areas facing each other are alternately loaded and/or relieved, which means that the load changes its direction constantly by approximately  $180^{\circ}$ .

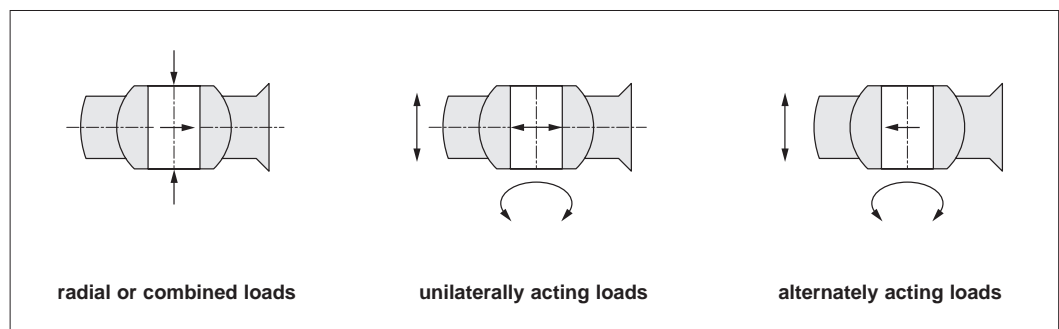

### Swivelling angle

The swivelling angle is the movement of the rod end from one final position to the other. Half the swivelling angle  $\alpha^{\circ}$  is used to calculate the service or 'working life'.

