

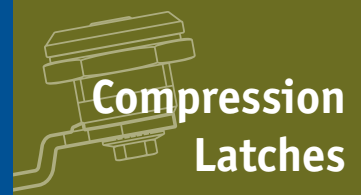

Mini Compression Latches

insert driver - adjustable grip - zinc



Compression Latches

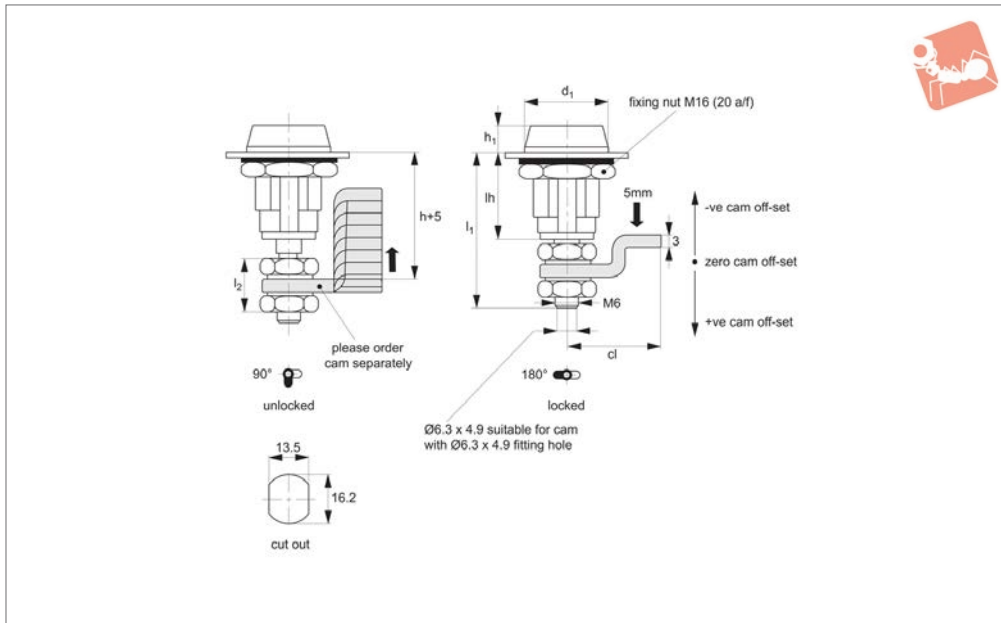

A1661

COMPRESSION LATCHES

Material

Body & insert: die cast zinc, black paint coated.

Insert fitted with O'ring to provide IP54 rating.

Not supplied: CAM nor KEY: order separately.

Technical Notes

Suitable for material thickness 1-10mm.

Order keys separately.

Cam: see suitable cam A0234. Select „without projection“ cam type.

Dimensions ch & cl relate to cam. Use

formula to calculate ch (required cam off-set), and refer to cam selection chart;

ch = h - lh where;

ch = required cam off-set/height.

h = grip length (distance between inside of lock face and front of cam).

lh = body length of cam latch/lock to be used.

Keys: see A0102. For part A16661.AW0006 (Square 6) use key A0102.AW0306 only.

Tips

Compression locks provide sealing of enclosures to reduce vibration and to

provide noise isolation. Adjustable grip type has an extended stem which can be cut in length to best suit your application.

Action:

From unlocked position, first 90° turn moves the cam to the locking position. Turn lock 210° to engage compression, cam moves to final fixing position.

Provides a 5mm compression stroke.

Order No.	Insert driver	d ₁	h ₁	lh	l ₁	l ₂ useful thread
A1661.AW0006	Square 6	20.8	6	22.5	38	15
A1661.AW0080	Slotted (2x4)	20.8	6	22.5	38	15