

36820

RETAINING CATCHES

Material

Dry powdered metal.

Technical Notes

Not suitable for welding. Secure by using pins.

Order No.	Type	d ₁	d ₂ tol. H8	d ₃	b ₁	b ₂	b ₃	b ₄	Weight g
36820.W0008	Lock-right	35	8	18	15	7	3	7.0	30
36820.W0010	Lock-right	35	10	18	15	7	3	7.0	31
36820.W0012	Lock-right	65	12	23	20	10	5	7.2	103
36820.W0016	Lock-right	80	16	27	24	12	6	8.8	174
36820.W0108	Lock-left	35	8	18	15	7	3	7.0	34
36820.W0110	Lock-left	35	10	18	15	7	3	7.0	31
36820.W0112	Lock-left	65	12	23	20	10	5	7.2	103
36820.W0116	Lock-left	80	16	27	24	12	6	8.8	175

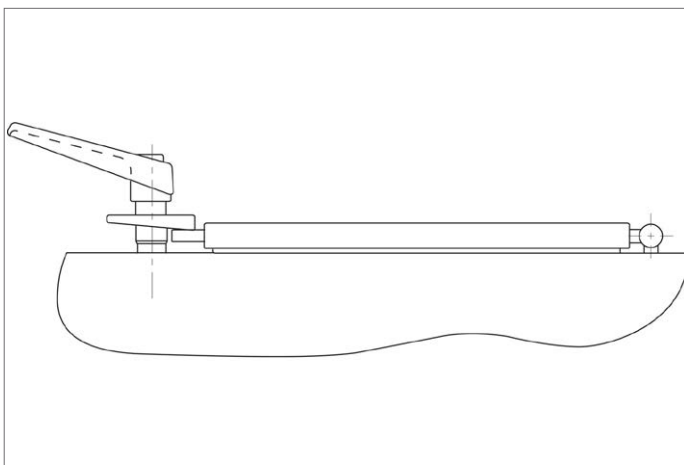



73900

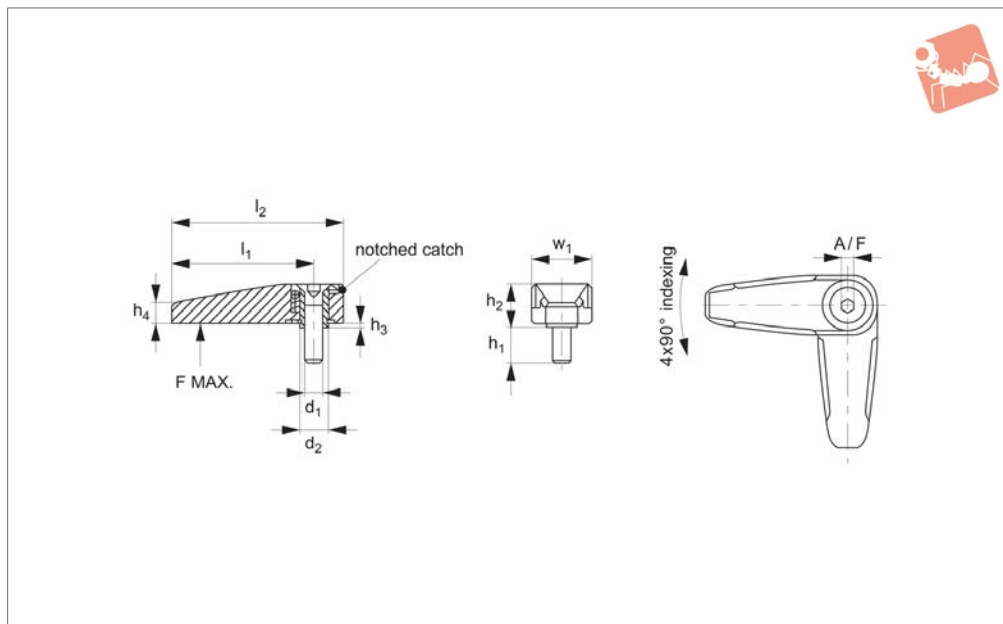

Material

Body: die cast zinc, black coated to RAL 9005 or silver coated to RAL 9006.
Fixing screw: stainless steel A2.

Inner parts: dry powdered metal.

Technical Notes

Quick retaining catch with positive inde-

xing. Ideal for retaining doors, panels as well as for retaining parts during transportation.

Retaining catch is indexed $4 \times 90^\circ$.

Order No.	Colour	d_1	d_2	l_1	l_2	h_1	h_2	h_3	h_4	Load F N max.	w_1	A/F	Weight g
73900.W0101	Silver	M 6	9	45	55	12	13.3	0.8	6.5	500	19.0	4	59
73900.W0102	Black	M 6	9	45	55	12	13.3	0.8	6.5	500	19.0	4	59
73900.W0151	Silver	M 8	14	65	78	14	15.8	0.8	9.0	1000	25.2	5	136
73900.W0152	Black	M 8	14	65	78	14	15.8	0.8	9.0	1000	25.2	5	136

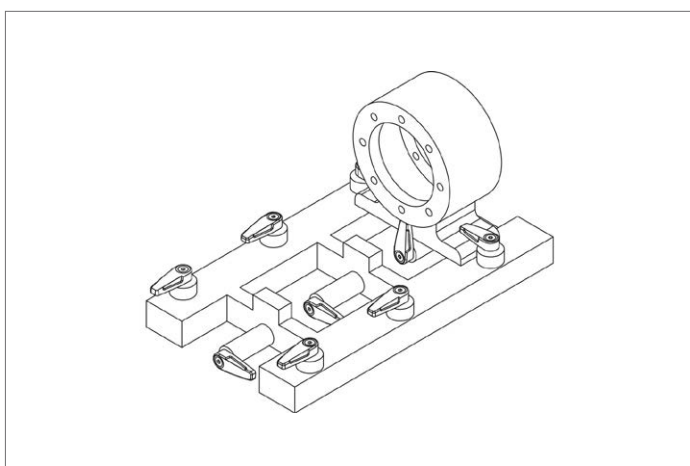

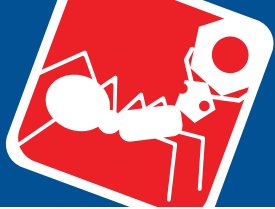

Retaining Catches



73900

Knobs, Handles & Handwheels

- Locking of panels and covers.
- Securing components during transport.
- Sturdy, solid design.
- Double sided model available.
- Indexes at 4 x 90°.

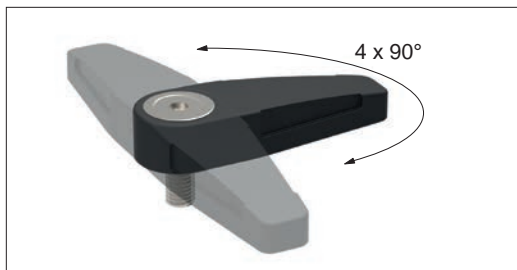

Single side

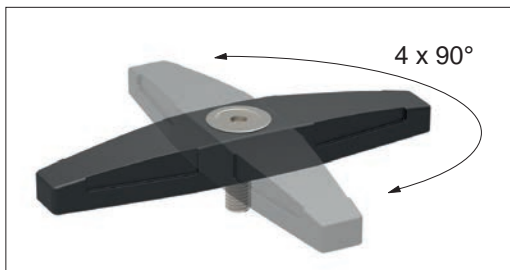

Double side

Models

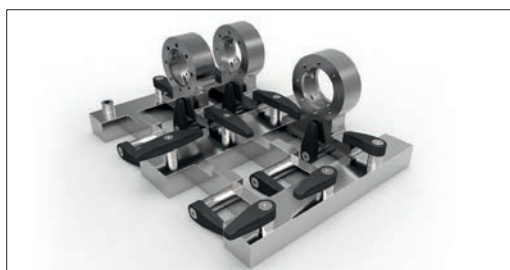
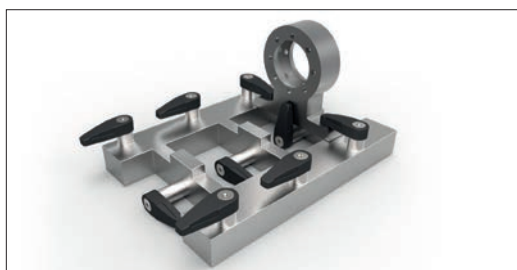

Applications

RETAINING CATCHES

Retaining Catches

73906

- Locking of drawers.
- Securing of panels and covers.
- Simple operation.
- Indexes at 4 x 90°.
- Three mounting options.

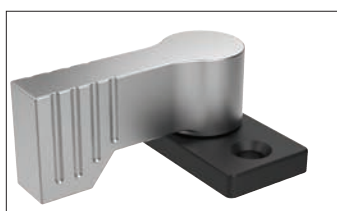

Flange



Female thread



Male thread

Mounting options



Applications

ov-W73900-A-T-a-rnh- Updated -27-10-2022



73902

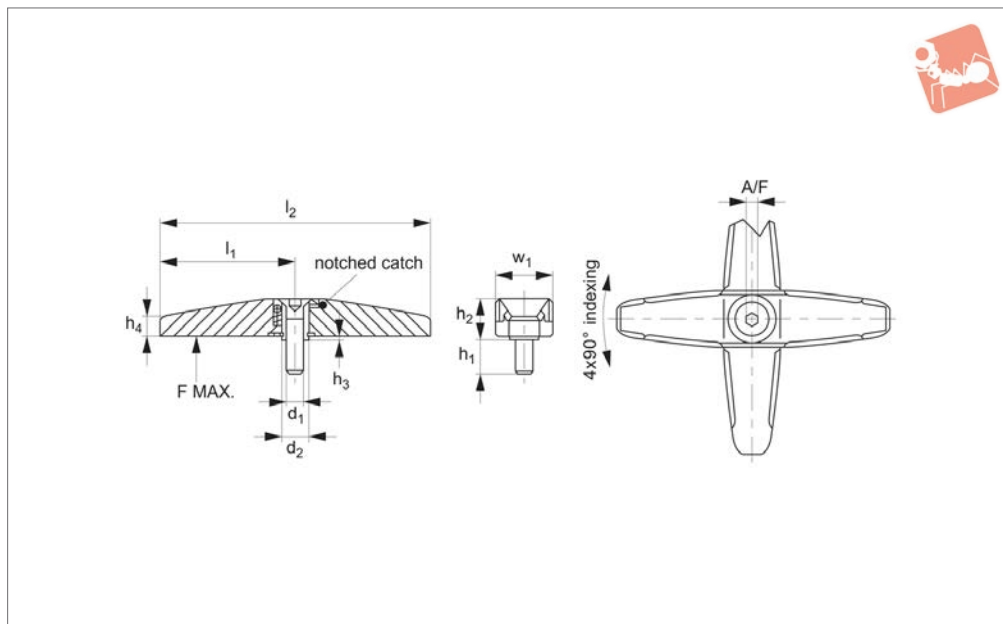

Material

Body: die cast zinc, black coated to RAL 9005 or silver coated to RAL 9006.
Fixing screw: stainless steel A2.

Inner parts: dry powdered metal.

Technical Notes

Quick retaining catch with positive index-

ing. Ideal for retaining doors, panels as well as for retaining parts during transportation.

Retaining catch is indexed 4x90°.

Order No.	Colour	d ₁	d ₂	l ₁	l ₂	h ₁	h ₂	h ₃	h ₄	Load F N max.	w ₁	A/F	Weight g
73902.W0601	Silver	M 6	9	45	90	12	13.3	0.8	6.5	500	19.0	4	93
73902.W0602	Black	M 6	9	45	90	12	13.3	0.8	6.5	500	19.0	4	93
73902.W0651	Silver	M 8	14	65	130	14	15.8	0.8	9.0	1000	25.2	5	220
73902.W0652	Black	M 8	14	65	130	14	15.8	0.8	9.0	1000	25.2	5	220

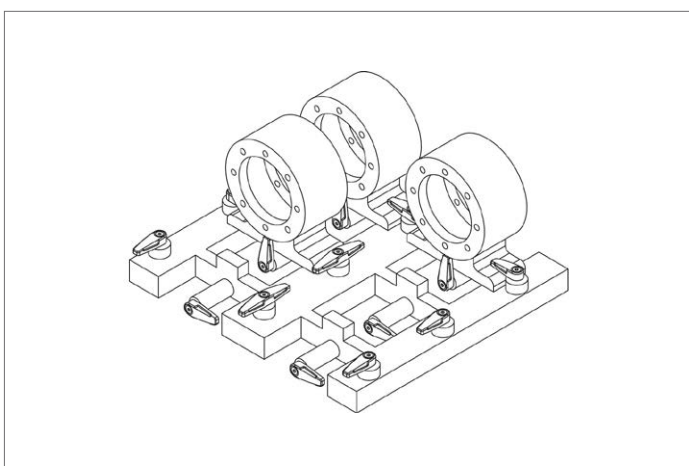

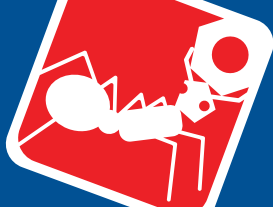

Retaining Catches

wing grip, one-sided



Retaining Catches

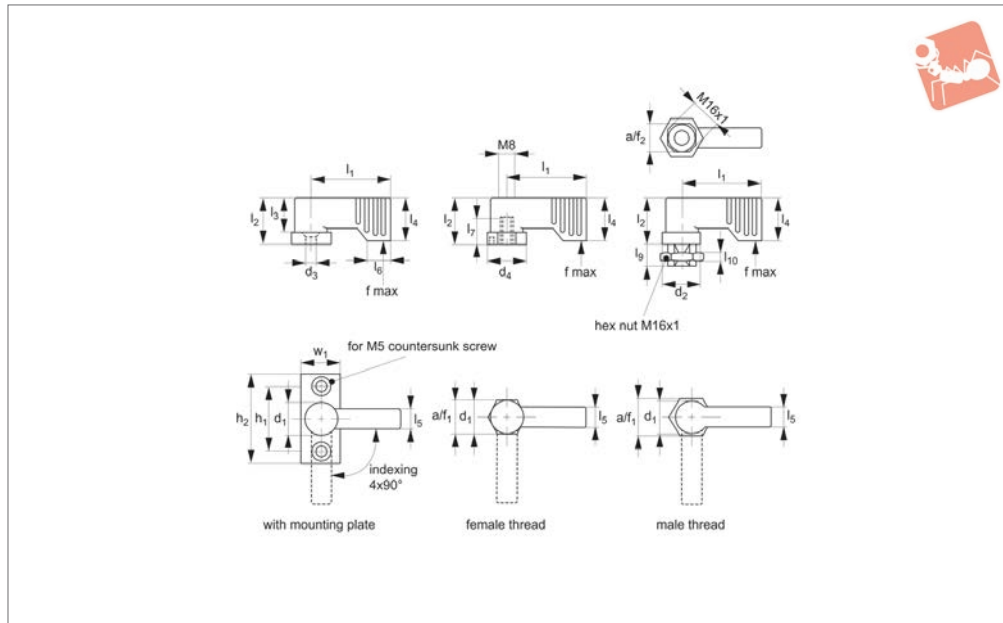

73906

RETAINING CATCHES

Material

Lever: die-cast Zinc, plastic coated silver (RAL9006) or black (RAL 9005) matte finish.

Flange: die-cast Zinc, plastic coated, black.

as a support during transports etc. The retaining catch indexes at 4x90°.

Technical Notes

To be used for locking doors, drawers and

Order No.	Colour	Type	d ₁	d ₂	d ₃	d ₄ ≈	d ₅	d ₆ tol. H11	l ₁	l ₂ ≈	l ₃	l ₄ min.	Weight g
73906.W0201	Silver	Mounting Plate	17	-	5.3	-	-	-	40	22	16.5	21.5	20
73906.W0202	Black	Mounting Plate	17	-	5.3	-	-	-	40	22	16.5	21.5	20
73906.W0232	Black	Female Thread	17	-	-	20	7	2	40	22	16.5	21.5	30
73906.W0262	Black	Male Thread	17	19	-	-	-	-	40	22	16.5	21.5	50
73906.W0231	Silver	Female Thread	17	-	-	20	7	2	40	22	16.5	21.5	30
73906.W0261	Silver	Male Thread	17	19	-	-	-	-	40	22	16.5	21.5	50

Order No.	l ₅	l ₆	l ₇	l ₈	l ₉	l ₁₀	h ₁	h ₂	w ₁	A/F ₁	A/F ₂	Load f max. N
73906.W0201	10	11	-	-	-	-	32	45	20	-	-	450
73906.W0202	10	11	-	-	-	-	32	45	20	-	-	450
73906.W0232	10	11	11	4	-	-	-	-	-	17	-	450
73906.W0262	10	11	-	-	9	3	-	-	-	19	14	450
73906.W0231	10	11	11	4	-	-	-	-	-	17	-	450
73906.W0261	10	11	-	-	9	3	-	-	-	19	14	450