

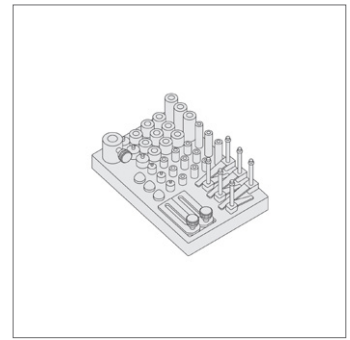

Basic CMM Fixturing Set for M 8 threads

Gauging & Inspection

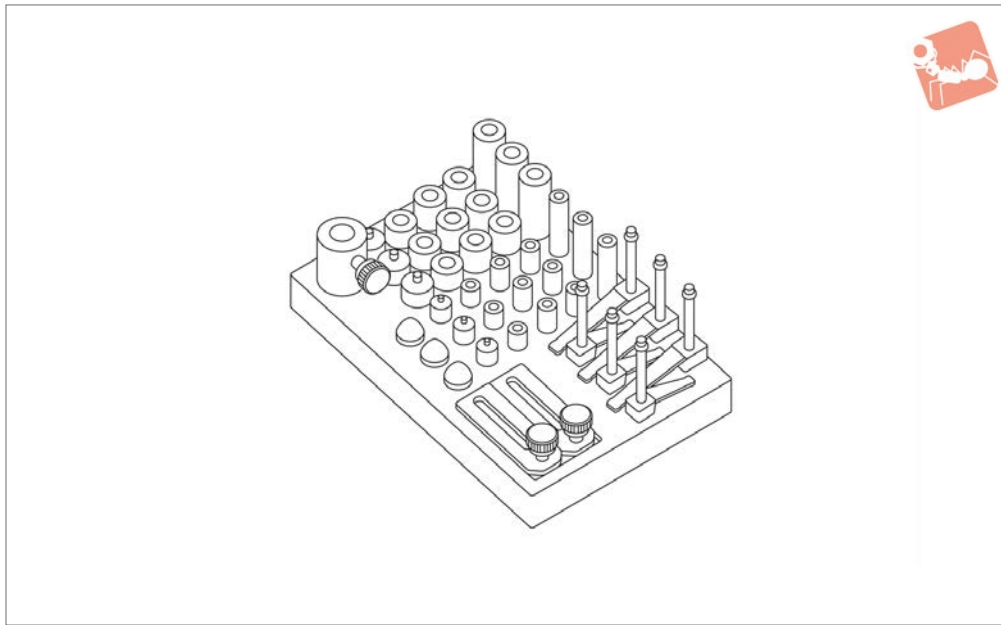

19310

GAUGING & INSPECTION

Technical Notes

Designed for clamping non-magnetic parts on CMM tables.

Important Notes

M 8 coarse thread. Basic set of workholding

components for fixturing of components on CMMs. Components are of lightweight materials: aluminium, plastic etc. to avoid damage to components. Supplied on wooden holder for easy and tidy storage.

For CMM fixturing plates and towers see 19300 and 19302.

Order No.	Soft touch clamp 19320	CMM fixturing stand-off 19330		CMM fixturing stand-off with pin 19331	CMM fixturing positioning cone 19332	CMM fixturing adj. positioner 19354	CMM fixturing stand-off adjustable 19350	Weight g
19310.W0008	.W0008 x 3pcs .W0012 x 3pcs	.W1320 x 3pcs .W1350 x 3pcs .W1925 x 6pcs	.W1325 x 6pcs .W1920 x 3pcs .W1950 x 3pcs	.W1325 x 3pcs .W1925 x 3pcs	.W001613 x 3pcs	.W2835 x 2pcs	.W0028 x 1pc	2800

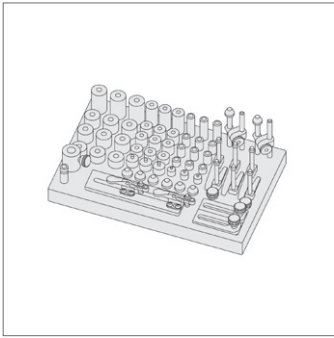

19312

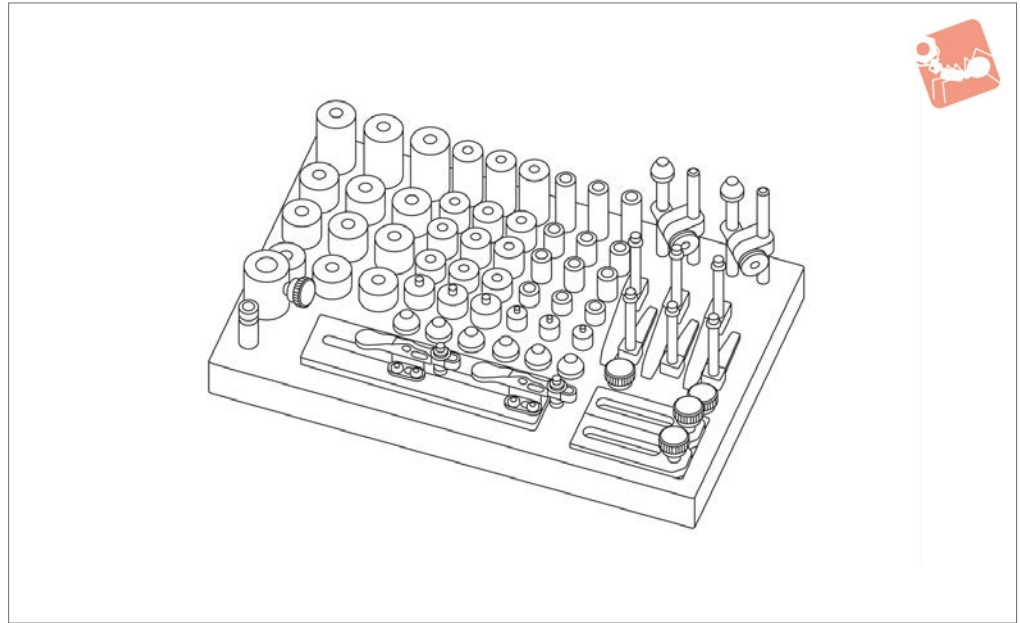

Technical Notes

M8 coarse thread. Comprehensive set of workholding components for fixturing

components on CMMs. Components are of lightweight materials; aluminium, plastic etc. to avoid damage of workpieces. Supp-

plied on a wooden holder for easy and tidy storage. For CMM fixturing plates and towers see parts 19300 and 19302.

Order No.	Soft touch clamp 19320	CMM fixturing stand-off 19330			Toggle clamp 19322	Weight g
19312.W0008	.W0008 x 3pcs .W0012 x 3pcs	.W1320 x 3pcs .W1325 x 6pcs .W1350 x 3pcs .W1920 x 3pcs .W1925 x 6pcs .W1950 x 3pcs .W2520 x 3pcs .W2525 x 6pcs .W2550 x 3pcs			.W0075 x 2pcs	4600
Order No.	CMM fixturing stand-off with pin 19331	CMM fixturing positioning cone 19332	CMM fixturing adj. positioner 19354	CMM fixturing stand-off adjustable 19350	CMM fixturing screw jack 19352	CMM fixturing adjustable stop 19358
19312.W0008	.W1325 x 3pcs .W1925 x 3pcs	.W001613 x 3pcs	.W2835 x 2pcs	.W0028 x 1pc	.W1945 x 1pc	.W0008 x 2pcs



CMM Fixturing Magnetic Stand-off Set for M 8 threads

Gauging & Inspection

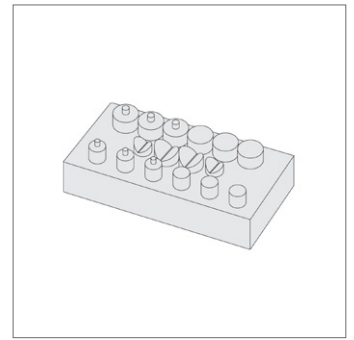
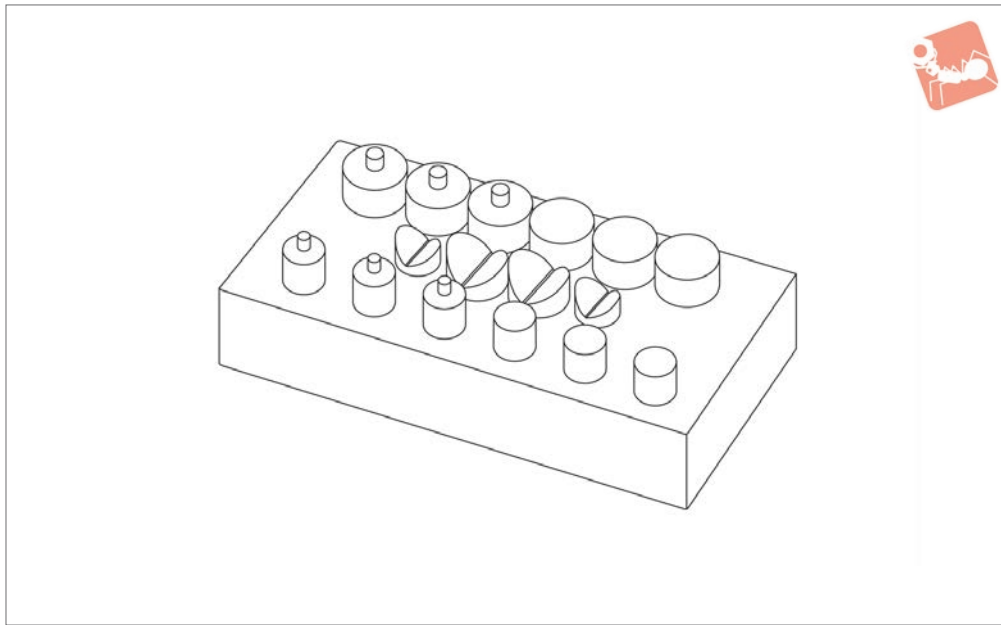

19314

GAUGING & INSPECTION

Material

Magnets in brass sleeves, in wooden holder.

Tips

Use with steel and iron components.

Order No.	CMM fixturing magnetic rest buttons 19336	CMM fixturing magnetic stand-off with pin 19337	CMM fixturing magnetic vee stand-off 19338
19314.W0008	.W1325 x 3pcs .W1925 x 3pcs	.W1325 x 3pcs .W1925 x 3pcs	.W1325 x 2pcs .W2525 x 2pcs

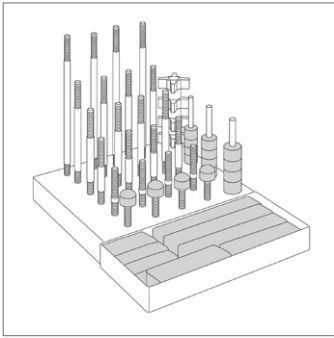

19370

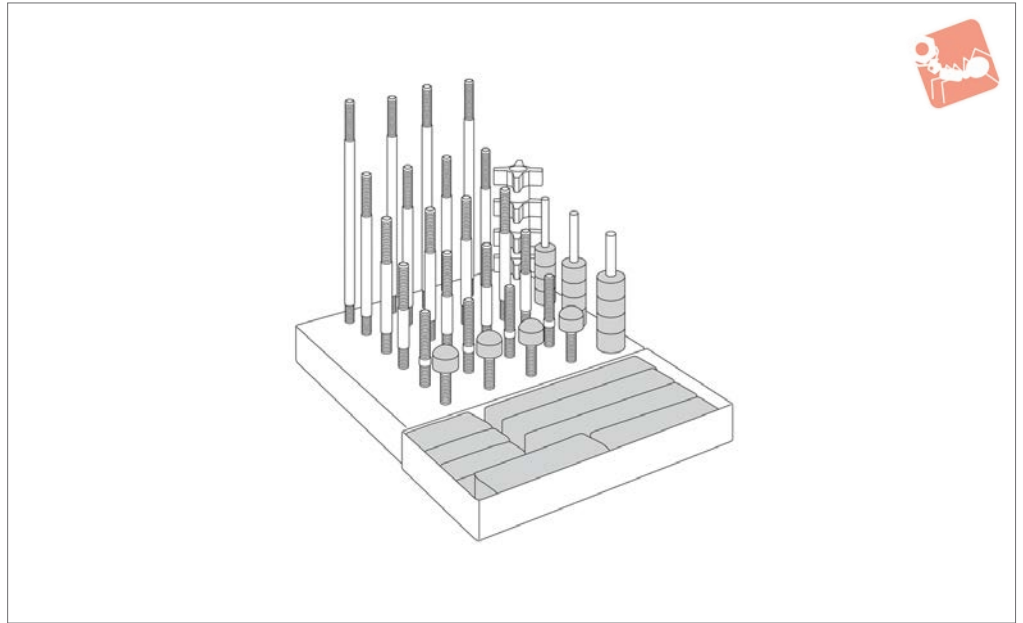

Material

Clamps, rest feet: nylon 101.
 Studs, coupling nuts and washers: steel.
 Supplied in metal tray for improved organi-

sation.

Tips

Lightweight components reduce risk of

damage to the CMM table.

Order No.	Thread size	Studs	Nylon clamps	Extension nuts	Nylon star knob	Support feet	Nylon washers	Weight g
19370.W0008	M 8	50mm x 4pcs 75mm x 4pcs 100mm x 4pcs 125mm x 4pcs 150mm x 4pcs	63mm x 4pcs 90mm x 4pcs 115mm x 4pcs	M 8 x 4pcs	M 8 x 4pcs	M 8 x 4pcs	for M 8 x 8pcs	2495
19370.W0010	M10	50mm x 4pcs 75mm x 4pcs 100mm x 4pcs 125mm x 4pcs 150mm x 4pcs	63mm x 4pcs 100mm x 4pcs 150mm x 4pcs	M10 x 4pcs	M10 x 4pcs	M10 x 4pcs	for M10 x 8pcs	2857
19370.W0012	M12	50mm x 4pcs 75mm x 4pcs 100mm x 4pcs 125mm x 4pcs 150mm x 4pcs	63mm x 4pcs 100mm x 4pcs 150mm x 4pcs	M12 x 4pcs	M12 x 4pcs	M12 x 4pcs	for M12 x 8pcs	4991



CMM Fixturing

modular approach, flexible system

19300 - 19370
Clamping & Height Setting

Wixroyd's CMM fixturing system is designed for easy assembly and high repeatability, eliminating the need to build dedicated fixtures. The system offers a highly accurate and flexible solution of holding parts while probing on CMMs.

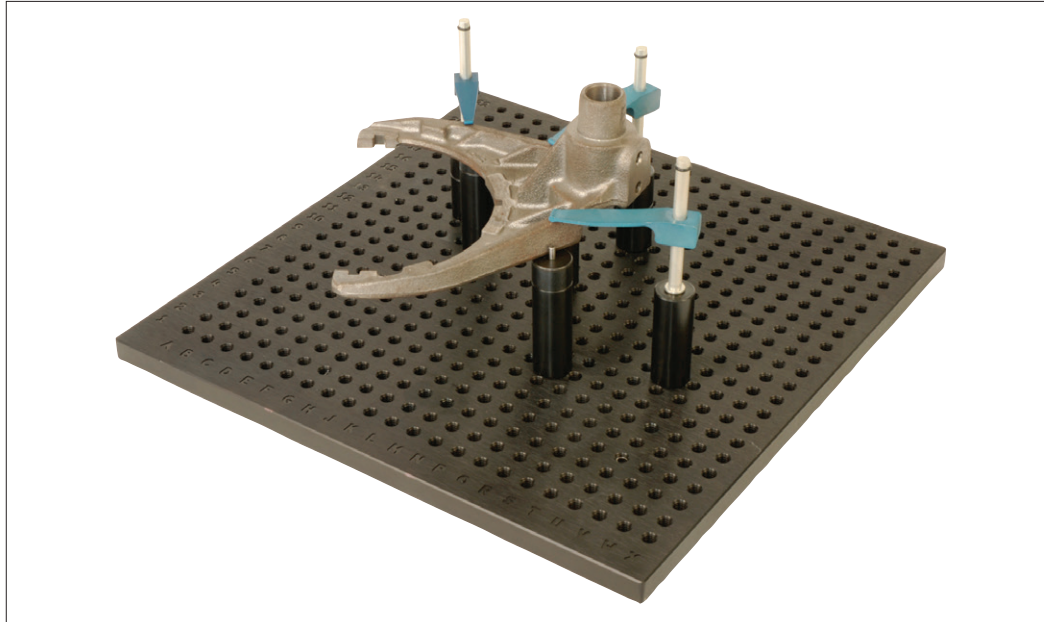

Flexible

A variety of component parts as well as complete kits are available; to enable setup of fixtures in minutes.

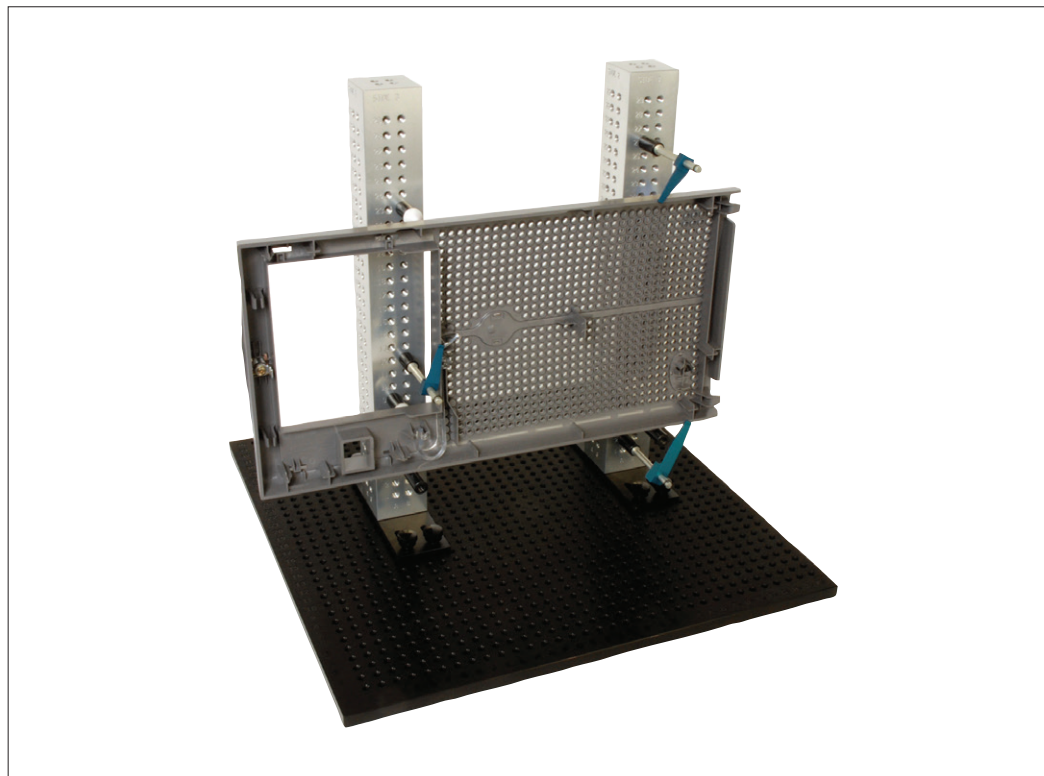

- Aluminium base plates – hole based system with alpha-numeric labelling for easy set-up and recording of fixture positions.
- Fixture towers – ideal for fixturing of large vertical components.
- Soft-touch clamps – non-marking clamps providing the ideal force for holding parts during CMM probing.
- Locating components – rest pads, vee pads for cylindrical parts, pin rests etc.